

## Cable canal protector

[www.rm-intgroup.com](http://www.rm-intgroup.com)

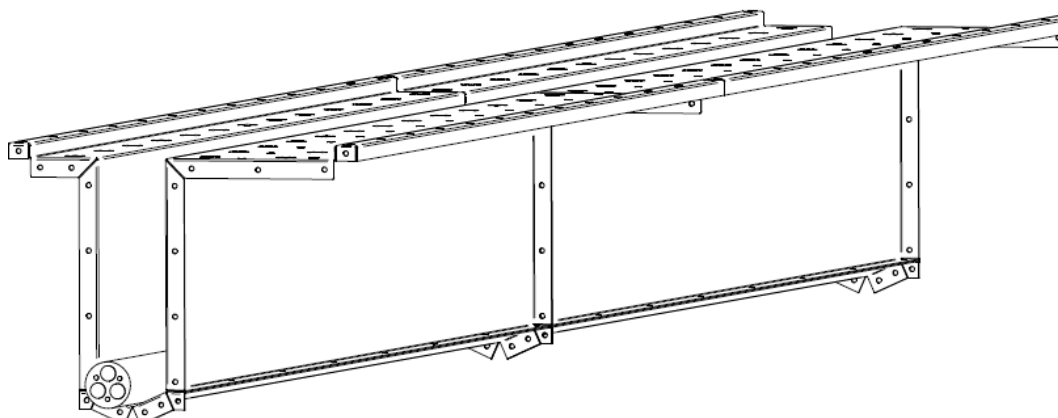

Cable Canal Protector is an effective solution to protect the power cables in cable canals in ports and similar terminals. The cable is placed in a special gutter made of steel and closed with a protective belt.



When used in ports for marine conditions, the gutter is made of stainless steel. The protective belt is a reinforced rubber product.

Special design development of the protective belt allows it to be rigid in the transverse direction and flexible in the longitudinal direction. Flexibility in the longitudinal direction makes it easy to lift the guide rail, and stiffness in the transverse direction withstands the enormous weight of moving freight vehicles.

The functions of this protective system are divers:

- Protection of expensive cable, allowing its long-term operation.
- The cable channel protection system prevents any material from entering the cable channel and minimizes the need for channel maintenance.
- Effective use of expensive area in ports and freight transport without restrictions.
- The protection system for cable channels is resistant to mechanical and abrasive influences, as well as weather and environmental conditions commonly observed in ports

### Technical details

Operating temperature:	-30+80 °C * for special winter low-temperature snow conditions - special production -40+80°C
Opening angle	90°
Horizontal bending radius:	35 m (min) with hinge profile external 45 m (min) with hinge profile internal
Maximum load	The maximum load applied on a belt with a 100 mm wide slot should be 400 N/ cm <sup>2</sup>
Elongation	2% with a load of 3000 N
Max.force to open the belt at 90°:	40 кг
Materials:	76 % SBR – Styrene – butadiene - rubber 15 % steel cord 9 % nylon
Reinforcing:	Two layers of RFL dipped nylon yarn - breaking load 50 kN/m Two layers of RFL dipped nylon fabric - breaking load 160 kN/m Brass coated steel cord - breaking load 640 kN/m Two layers of RFL dipped nylon fabric - breaking load 55 kN/m

**The cable protection system is designed and made to order for exact specifications. Company RM International Group Sp. z o.o. reserves the right to make structural changes to any element.**

The protective belt is delivered in rolls of 50 meters. The gutters have an installation length of 2 meters. Elements are prepared for quick comfortable installation. Robust packaging designed for safe transport.